





PAN CONNECTORS
60MM OFFSET

- No need to solvent weld, push into pipe
- Install as per 3500.2
- High rise reduces the risk of siphonage and may need to be recessed into the floor
- Do not install offset pan connectors on P Trap toilets, doing so will void the warranty
- Ensure the outlet of the WC does not come into contact with the base of the pan connector body
- Standard Plastec warranty applies



ID	 DIAMETER	 BAG QTY
DWV 14751	100	22

ID	 DIAMETER	 BAG QTY
HDPE 14757	100	28

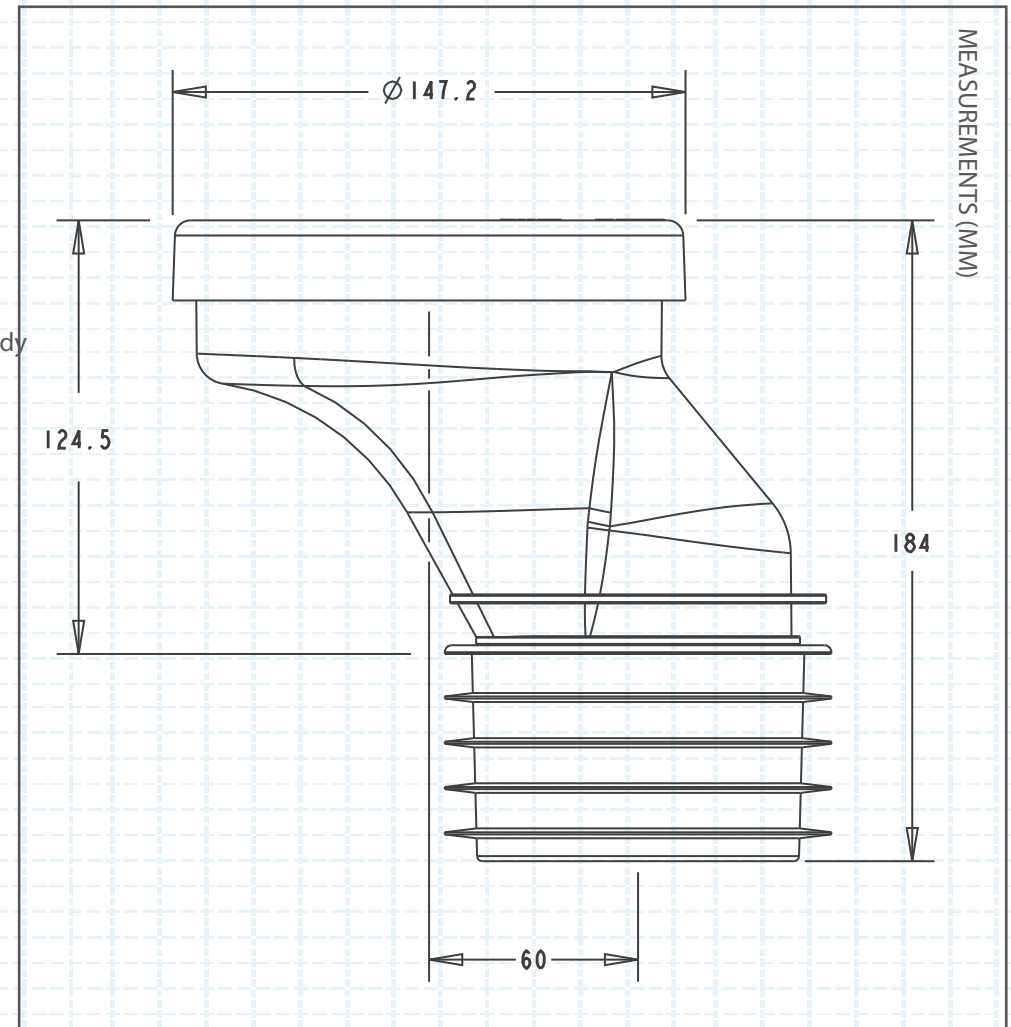

 DIAMETER  FASTENING  BAG QTY  CARTON QTY  FINISH/COLOUR  MEASUREMENT (MM)

Details correct as at 27.05.24, but are subject to change.