



PLASTEC

SWIVEL & EXPANSION JOINTS

DWV COMBINATION JOINTS 120MM EXPANSION

- Compact fitting
- Allows for 40 degrees inclusive swivel movement
- Allows for 120mm maximum expansion
- Suitable for use within M, H1 & H2 class soil sites
- Ideal first fitting from the footing on all sites susceptible to movement



ID	INLET	OUTLET	MAX EXP
18634	100 Pipe Size	Socket	120 8
18635	100 Pipe Size	Pipe Size	120 8
18739	100 Socket	Socket	120 6

RELATED PRODUCTS: • DWV 52mm expansion and 80mm expansion Combination Joints also available • HDPE compatible Combination Joints also available.

PRODUCT SPECIFICATIONS

MEASUREMENTS (MM)

ID	A.	B.	C.
18634	374	179.4	180
18635	376	179	180
18739	376	179	180

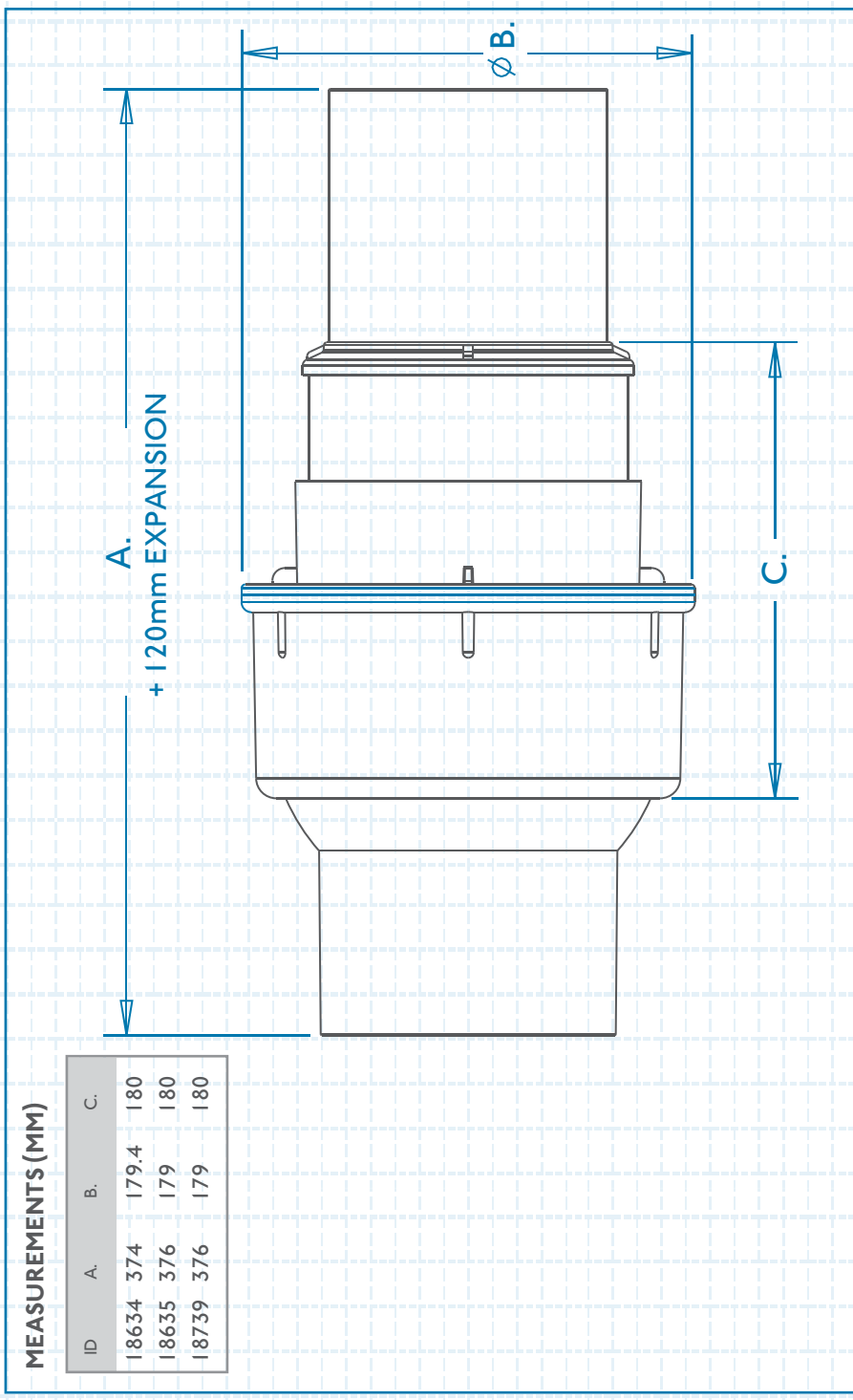

WMTS055

PH: 07 5413 4444 WWW.PLASTEC.COM.AU

DETAILS CORRECT AT TIME OF PRINTING (25.01.2016), BUT IS SUBJECT TO CHANGE



DIAMETER (MM)



FASTENING



BAG QTY



CARTON QTY



FINISH/COLOUR



MEASUREMENT (MM)